

KEK Kibblers

Lump Breakers and Pre Breakers



- » Robust design
- » Slow speed / High torque
- » Quick screen changes
- » Hygienic and easy to clean



Strong and robust KEK Kibbler's are designed to grind large lumps of up to (150 mm) and reduce them to (2-3 mm) in preparation for further processing. The lump breaking process takes place through a combination of impact, crushing, cutting and abrasion. While the slow speed, heavy-duty beater, sweeps product against the contoured grinding screen.

FEATURES:

- » Food grade contact parts throughout
- » Food grade metal detectable seals and gaskets
- » Cantilever design
- » Hinged and interlocked access doors
- » Low speed, high torque
- » Various motor configurations
- » Variety of screen and beater configurations
- » Customisable i.e. clean in place / extra hinge doors

COMPLIANCE:

- » EU 1935/2004 and ISO 9001
- » 98/37/EC European Machinery Directive
- » ATEX 2014/34/EU

BENEFITS:

- » Reliable machine for continuous processing and minimum downtime
- » KEK cantilever design minimises maintenance points and increases accessibility
- » Easy clean and hygienic
- » Configurable for a wide range of products, applications and size distributions

APPLICATIONS:

- » Densification of larger particle products
- » Pre break for product rework prior to milling
- » Particle size reduction to create a more easily conveyed product
- » Product rework grinding

KEK Kibblers Data Table

KEK Kibblers Unit Size	M203	M303	M305	M311	M505
Cantilever Design	•	•	•	On request	On request
ATEX Availability	•	•	•	On request	On request
Typical Unit Dimensions					
Height (mm)	350	450	490	On request	On request
Length (mm)	500	600	600	On request	On request
Approx. Net Weight (kg)	190	190	420	On request	On request
Motor Size (hp)	4	4	7.5	On request	On request
Motor Size (kW)	3	3	5.5	On request	On request
Available Screens	Conidur 1-4 mm, raised lip 5-25 mm, square 5-25 mm Conidur (serrated), square hole, round hole				



PIN BREAKER



M203C



M303C



M305C



M505



M305



M311

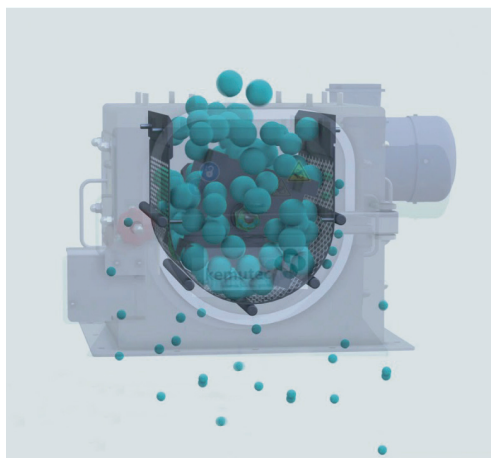

U-Trough Screen

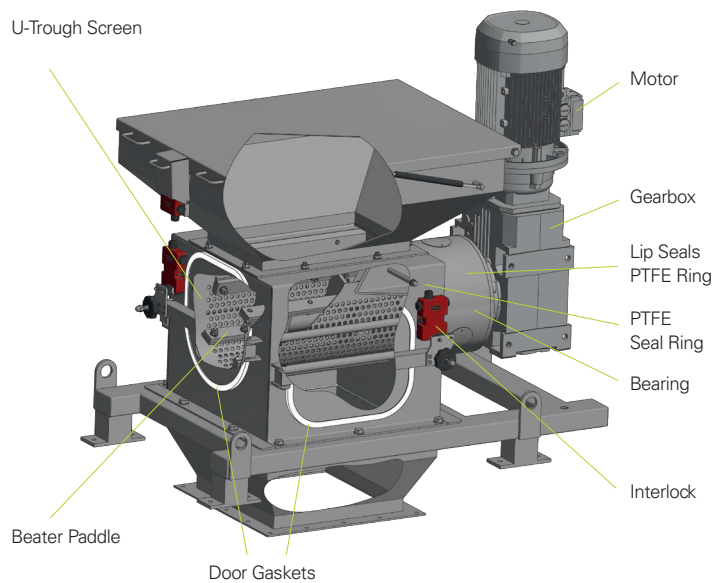

Spares and Servicing are available, to talk to one of our experts please call: +44 (0)1625 412000